

YOUR POWER TO SUCCESS

BEST FUEL ECONOMY
BEST COST OF OWNERSHIP

BEST IN RELIABILITY
BEST IN CLASS SERVICE



You can rely on us...

EICHER ENGINES
AIR COOLED

TMTL ENGINES
WATER COOLED

#IndiaKaEngine



FEATURES & BENEFITS

ENGINE

Cutting Edge Technology	Best in Class Fuel Efficiency Lowest Maintenance Longest Oil Change Period Longest Overhauling Period Most Economical Genset
A 1 Governing	Quality of Power Lowest Flickering and Fluctuation
High Moment of Inertia and Torque	Best in Class Block Loading Capability Better Performance at Varying Loads
Individual Blowers (Air Cooled Range)	Even cooling of all the cylinders Better efficiency
Turbo Charger with Inter Cooler (Water Cooled Range)	Better Engine Efficiency
Most Reliable Engines	Prime Power Rating available across range Most Powerful Engines in their Class

ACOUSTIC ENCLOSURE

CRCA Sheet	Longer Life
40 mm PU Foam (5 to 60 kVA)	Thickest in its class Low noise and vibration level Super Silent Options available
Silencer Inside the Canopy	Better Aesthetics Longer life of Silencer
Compact Size	Saves Space Suitable for roof top installation
Large Doors on Both Sides Drain Provided for Lube Oil and Fuel Tank	Ease of Maintenance
Unitary Front and Back Panel Canopy with Internal Bolting Stainless Steel Hinges with SS Studs SS Slam Locks with Barrel & Padlock arrangement	Higher Degree of Safety
Dual Fuel Lock S-bend Fuel Pipe Stainless Steel Fuel Strainer	Pilferage Proof
State of Art Powder Coating Plant	Long Life Weather Protection

BEST IN CLASS SERVICE

Single Point of Contact Round the Clock Assistance Pan India Service Network Highly Qualified & Trained Service Team Post Service Feedback Mechanism	Delighted Customer
--	--------------------

WARRANTY TERMS

Warranty period covers 2 Years or 5000 Hours run* (whichever is earlier)

* Terms and conditions apply

PRIME POWER (PRP)

Applicable for supplying power to varying electrical load for unlimited hours.

Prime Power (PRP) is in accordance with ISO 8528.

10% overload capability is available in accordance with ISO 3046, AS 2789, DIN 6271 and BS 5514.



Controller: DSE4522 MK1

KEY FEATURES OF DSE 4522 CONTROLLER

- LCD display
- True RMS Voltage
- Current and Power monitoring
- USB Communications
- Engine parameter monitoring.
- Fully configurable inputs for use as alarms or a range of different functions.
- Engine ECU interface to electronic engines
- The DSE smart PC Software allows
- Alteration of selected operational sequences,
- Timers, alarms and operational sequences.
- **Operating Temperature:** -30 °C +70 °C (-22 °F +158 °F)
- **Operating voltage:** 8 V to 32 V DC
- **COMMUNICATION PORTS :**
- USB Port: Type B USB 2.0 For connection to PC
- Configurable digital inputs/output
- Generator running hours counter
- Three phase sensing
- Generator Power Monitoring like, Kilo watts / KV/Amp / Ar / Power factor
- Generator Protections like, Over load, Over voltage , Low Voltage, Single phasing
- Engine Protection like, Low RPM, High RPM, Low Lube oil , High Temperature
- Event Log
- Generator monitoring like, Battery Voltage, Engine run time scheduler ,
- Maintenance Alarm
- Automatic transfers between Generator and utility (Mains) transfer facility is available
- Remote Start / stop facility
- IP42 (front of module when installed into the control panel WITHOUT being sealed to the panel)
- IP65 (front of module when installed into the control panel with the optional

TECHNICAL SPECIFICATIONS

Technical Specifications - 15KVA

Genset Rating	kVA	15
Duty	Prime / Standby	Prime
Engine manufacturer	-	TAFE Motors and Tractors Limited
Engine Brand	-	Eicher Engines
Engine model	-	220A0-EG015
Number of cylinders	nos.	2
Aspiration	-	Naturally Aspirated
Engine power (gross)	BHP	25.7
Rated speed & frequency	RPM /Hz	1500/ 50 Hz
Stroke	mm	125
Bore	mm	100
Displacement	cc	1963
Compression ratio	-	17:01
Reference standard	-	BS: 5514, ISO: 3046, IS: 10000, ISO: 8528
Type of governer	-	Mechanical
Class of Governing	-	G2
Air cleaner	-	Dry
Type of cooling	-	Air Cooled
Fuel Tank Capacity	L	80
Lube oil Sump capacity (with filters)	L	8
Phase	-	1 Phase-2 wire / 3Phase-4 wire
Voltage	VAC	230/ 240, 415
Voltage Regulation	%ge of Rated voltage	+/- 1%
Power Factor	Lag	0.8
Power Alternator Type	-	Single Bearing, Brushless
Insulation	-	Class-H
Make	-	Stamford / Leroy Somer / CG or equivalent
Starting System	-	Electric
Battery	Volts, Ah	12 Volts, 88 / 90 Ah
Silencer Location & Type	-	Internal / Residential
Acoustic Insulation Type	-	PU FR- Acoustic Foam
Acoustic Insulation Thickness	mm	40
DG Set Dimensions (L X B X H)	mm	1800 x 900 x 1275
Weight of DG Set (Approx)+	kg	900

Dimensions and Weight

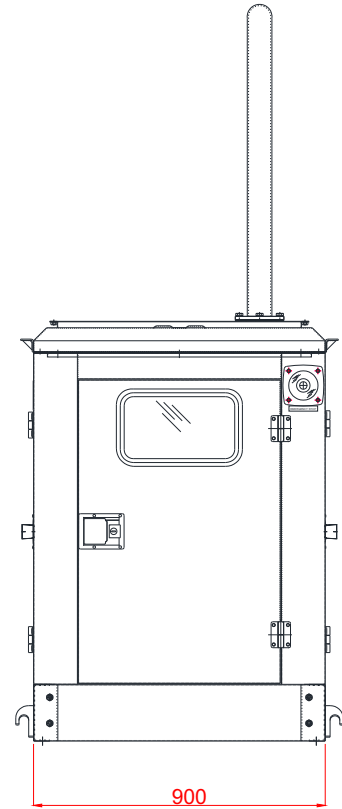
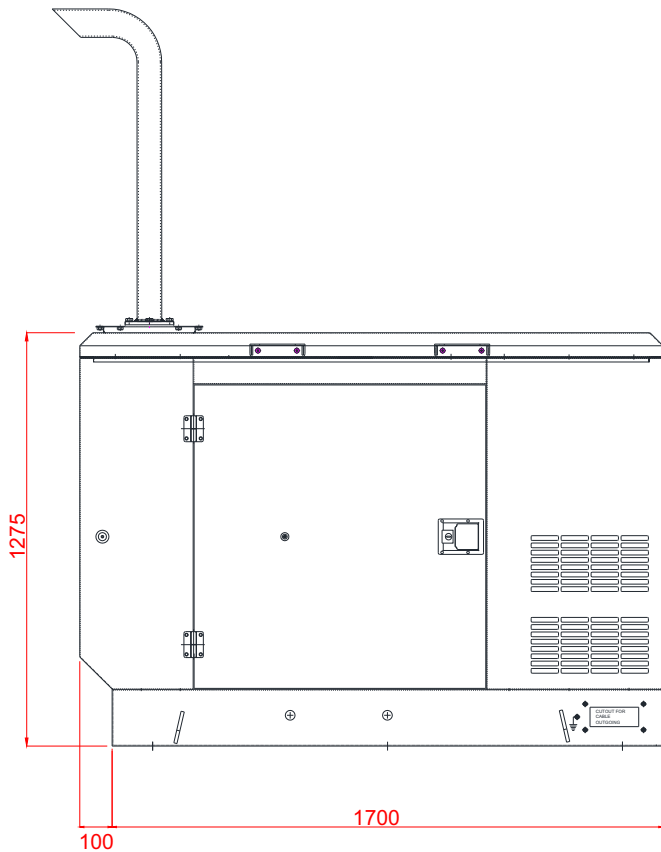

Overall Size (L x W x H): 1800 X 900 X 1275

Weight (Dry, Max): 900 Kg

NOTE: Drawing provided is for reference only and should not be used for planning installation . Please contact the company or latest updated details. All the data is as per respective manufacturer's specifications . MARSZ reserves the right to change the design or specifications without notice and without any obligation or liability whatsoever .

Disclaimer: Due to continuous product improvements, specifications are subject to change without prior notice.



Marsz Electricals (P) Ltd.

Registered Address

Balaji Tower, C-607/30, Vashi,
Opp. Sanpada Station (W),
Navi Mumbai - 400705

Contact us at:

WEBSITE: www.marszelectricals.com

Email: sales@marszelectricals.com

Telephone: +91 9322133738

Helpline: +91 7021943790